





DESIGN AND DEVELOPMENT OF A STROKE REHABILITATION GLOVE FOR MEASURING AND MONITORING HAND MOTIONS

Salman Muhammad Ilyas¹, Syed Faraz Jawed^{2*}, Choudhary Sobhan Shakeel³,
Luqman Hashim Bawany⁴, Rumaisa Amin⁵

¹PhD Scholar Biomedical Engineering TU Dresden, Germany 

^{2*}Associate Professor Biomedical Engineering Ziauddin University, Karachi, Pakistan 

³Lecturer Biomedical Engineering Ziauddin University, Karachi, Pakistan 

⁴Student Biomedical Engineering Ziauddin University, Karachi, Pakistan 

⁵Student Biomedical Engineering Ziauddin University, Karachi, Pakistan 

ABSTRACT

Muscular weakness tends to increase very rapidly due to various medical illnesses such as stroke, paralysis, fibromyalgia, etc. In order to keep tracks of the rehabilitative progress of patients who are suffering from such diseases, it is necessary to acquire data pertaining to finger movements including flexion and extension. Along with range of motions of proximal interphalangeal (PIP), distal interphalangeal (DIP) and meta-capo phalangeal joints, pinching strength is also vital in assessing the progress of rehabilitative therapies. Hence, our objective is to develop an assistive technology in the form of a smart glove comprising of flex and force sensors for measuring flexion and extension movements as well as the pinching strength. To the best of author's knowledge, commercially available rehabilitation gloves are expensive and have some limitations such as being non-portable, having an antenna mount on the gloves facing upward and so on. The

smart glove was able to measure the flexion and extension of finger movements and pinch strength with low-power requirements and low cost associated with production. The flexion and extension of finger movements along with pinching strength of stroke survivors was measured with the aid of the glove and showed promising outcomes. Through the results achieved by our developed glove, we were able to analyze the rehabilitative progress of stroke survivors. Moreover, the data is monitored continuously through liquid crystal display for rehabilitation purposes. Notably, this low-cost glove was designed with the aid of flex sensors and force sensors that enabled the effective measurement of flexion, extension and pinching strength of stroke survivors.

Keywords: *Paralysis, stroke, rehabilitation, assistive technology, flexion, extension, smart glove.*

Introduction

Hand motion abilities and functions are significant for executing daily routine activities and they encapsulate different types of movements such as extension and flexion¹. In order to assess the different types of movements executed via the hand, measuring the range of motion (ROM) and pinch strength is vital^{2,3}. It has been observed that any variation in

*Associate Professor Biomedical Engineering Ziauddin University, Karachi, Pakistan

Email: syed.jawed1@zu.edu.pk

Citation: Ilyas SM, Jawed SF, Shakeel CS, Bawany LH, Amin R. DESIGN AND DEVELOPMENT OF A STROKE REHABILITATION GLOVE FOR MEASURING AND MONITORING HAND MOTIONS. Pakistan Journal of Rehabilitation. 2022 July 7;11(2):177–188. Available from: <https://doi.org/10.36283/pjr.zu.11.2/023>

Received: Tues, Oct 5, 2021

Accepted: Tues, May 31, 2022

Published: Thurs, July 7, 2022

ROM and disability of the arm, shoulder and hand can exert an influence on pinch strength². Data pertaining to pinch strength and ROM is useful for diagnosis and pre and post planning of the rehabilitative treatment⁴. Furthermore, acquiring sufficient data relating to joint ROM via different assistive technology (AT) products can lead to an assessment about the treatment progress, patient's condition and information about patient's willingness to return to normal daily activities⁵. Therefore, measurements of joint ROM are one of the main quantitative methods for assessing hand abilities⁶.

Each year, thousands of people all over the world tend to experience difficulties due to serious brain injuries, articulation traumas and chronic diseases⁷. Among many types of brain trauma, the major causes of disorders are stroke, paralysis and fibromyalgia in adults⁸. Stroke, a leading cause of adult disability can be handled with adequate AT products and rehabilitative treatment in order to restore patient mobility and limb functions^{9,10}. It is predicted that in 2030 the population over 65 years of age will constitute 20% of the total population and will require some kind of AT and rehabilitative product. Under these circumstances, the increasing demand for rehabilitation treatments would rise significant¹¹.

Conventionally, goniometers have been used to measure ROM with the first one being developed in France that could measure plane angles¹². Following this, the cervical goniometer was developed to measure the ROM of elbow, forearm, ankle and the foot¹³. The universal goniometer is being used today for the measurement of ROM however, its use has been limited due to missing of relevant description about patient positioning and device placement¹⁴. The first electro goniometer, which converts angular motion of the joint into an electric signal, was developed. The use of electro goniometer is however limited due to their enhanced production cost and the time needed to calibrate and place them onto a patient^{15,16}.

These traditional methods of measuring ROM used in clinical settings are often not that appropriate to plan and evaluate rehabilitation treatments. Hence, for accurate measurements, gloves using different sensors have been designed for measuring ROM of hand joints¹⁷. Fifth Dimension Technologies (5DT) has manufactured a glove which can communicate wirelessly with a nearby computer^{18,19}. The White Hand Group has developed a cost-effective glove incorporating two sensors per finger with the help of fiber optics. The glove is mainly for virtual reality (VR) and gaming purpose rather than for correcting rehabilitation measurements¹⁸. A glove for measuring the flexion of hand joints with the help of potentiometers mounted at the back of the hand was introduced. Nonetheless, it was not durable for long term use. Flexion and hand gestures measurement in real time using inductive length encoders embedded in a cotton glove was developed. Limitations pertaining to this glove are the difficulty the user has to face while donning it on and the sensors can move around relative to the joint position and hence, can lead to inaccurate readings²⁰. A glove known as Cyber Glove has been developed and contains five to twenty-two patented bend-sensor technology strain gauges to measure movements of individual joints. However, this glove is very expensive and difficult to don for stroke survivors²¹.

To the best of the knowledge of authors, commercially available rehabilitation gloves are expensive and have some limitations such as being non-portable and encapsulating the requirement for an antenna mounted on the gloves that should be facing upward. Therefore, in this work an innovative smart glove which comprised of flex and force sensors has been designed for measuring the range of motion pertaining to the hand motions of the patient. This glove has the ability to measure the flexion and extension of finger movements and pinch strength with low-power requirements and low cost associated with production.

Methodology

Architectural Design

The design and development of the smart glove has been divided into three distinct regions which are sensing, signal conditioning and output display. The block diagram presented in Fig 01 demonstrates the generic flow of this work.

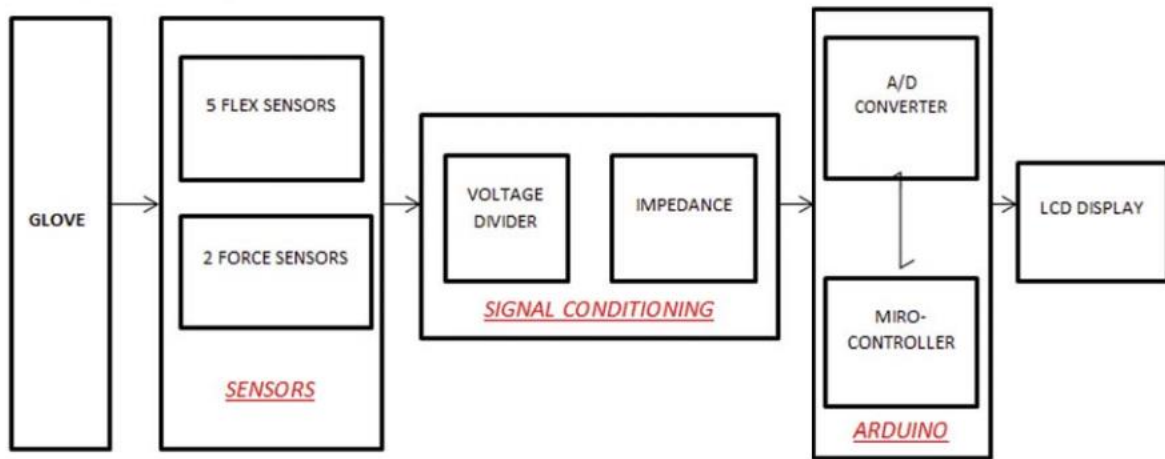

Figure 01: Block Diagram of Architectural Design

For selecting a comfortable material for glove fabrication, different materials such as nylon, Lycra, woolen and cotton have been tested as a glove material. However, woolen has found to be most appropriate material for glove fabrication because of its light weight, comfort and durability among the other aforementioned materials. Also, woolen material has good heat retention characteristics. Hence, we have used woolen as the glove material.

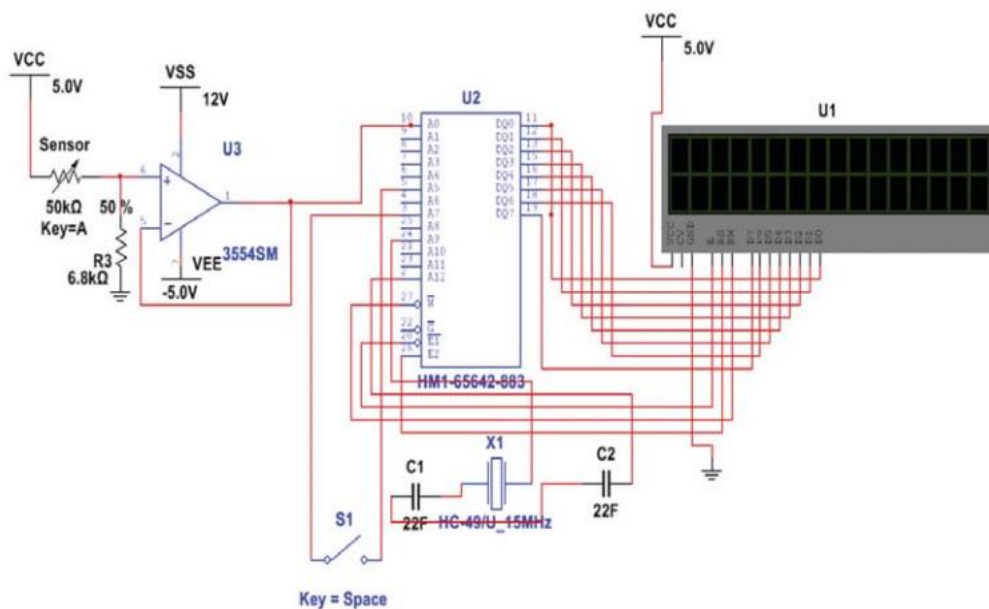

Figure 02: Schematic Diagram of Architectural Design

The sensing of the smart glove is made by using two sensors that are force sensor and flex sensor. There are 5 flex sensors and 2 force sensors have been employed on the glove. The working principle of flex sensor is that upon bending of sensor the resistance produces as per the change in the bending radius of the sensor. In this work, 5 flex sensors of 2.2" have been stitched in to gloves. The force sensor is a passive element and works as a variable

resistor. In this work, 2 force sensors of 10 mm each have been stitched in to glove at thumb position.

The schematic diagram of architectural design is shown in Fig 02. The signal conditioning is carried out using voltage divider circuit. The precise resistance values that are used in the voltage divider circuit (Fig 02) are $R1 = \text{variable resistance (i.e., } 10 \text{ K}\Omega \text{ to } 40 \text{ K}\Omega)$ and $R2 = 67 \text{ K}\Omega$. Further, impedance circuit is used in signal conditioning module for minimum deflections and maximum power delivery at output. The impedance circuit that is shown in Fig 02 is used for improving the signal condition.

The Arduino UN0 microcontroller is used. The microcontroller is connected with the sensing glove for retrieving the signals from flex and force sensors in order to get the results. The microcontroller has AD converter which converts the analogue results into digital and displays it on LCD (liquid crystal display).

Mechanical Assembly

The mechanical assembly of sensing glove includes three primary steps that are:

- Architecture of Arduino
- Interfacing of sensors with Arduino
- Assembling of circuit on the glove



Figure 03: Components of Mechanical Assembly

The tools that are required for the mechanical assembly of smart gloves are Arduino, soldering wire, soldering iron, resistance, force sensors; flex sensors, amplifier and LCD which is exhibited in Fig 03.

Software Implementation

The software comprises of a standard programming language compiler and a boot loader that runs on the microcontroller. The software system used in this work consists of an angle calculation code developed on Arduino IDE (Integrated Development Environment). The angle calculation code is used to calculate the range of motions (ROMs) of patient's fingers. The Arduino code for this work contains serial prints and delays to see the readings.

Algorithmic Approach

The algorithmic approach is based on the input which is acquired through glove when user moves the fingers, signal is read by microcontroller. Continuous analog signal is converted

into digital value which is displayed on LCD. If the input is constant, it will show the same value till the changes occur. The flow chart of final algorithmic approach is shown in Fig 04.

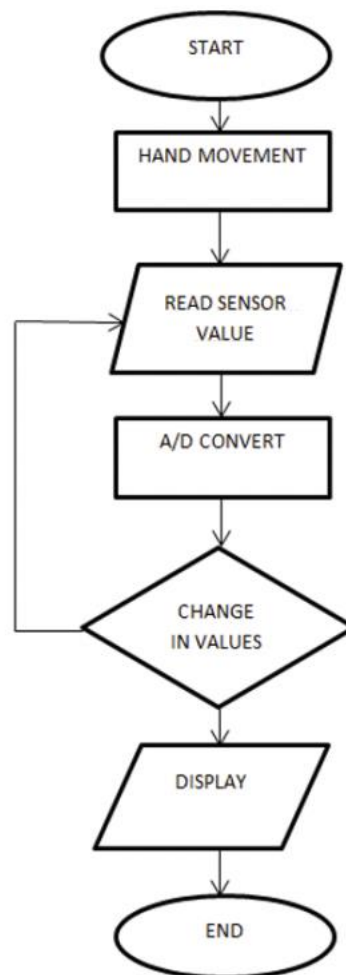

Figure 04: Flow Chart of Algorithmic Approach

Data Collection from Hospital Site

After successful fabrication of the smart glove, the pilot study was performed on fifteen stroke patients and their flexion readings were acquired. The data of seven patients were reported in this study. They were undergoing different rehabilitation therapies and data was recorded at the end of the activities. After 15 days, the second hospital visit was executed and flexion readings of the same seven stroke patients, involved during first data collection, were acquired. The results of data collection have been reported in subsequent section.

Results

A flex sensor was used to observe the change in LED (light emitting diode) brightness with the change in resistance when the sensor was subjected to bending. LED and flex sensor were connected to pin 3 and pin A0 of Arduino respectively. Increase in the bending of sensor increases the resistance and intensity of LED. Table 01 demonstrates the standard and observed value of flex sensor. Standard value has been acquired via datasheet whereas observed value corresponds to the millimeters reading.

Value	Resistance when sensor is straight	Resistance when sensor is fully bend
Standard value	30kΩ	70KΩ
Observed value	25KΩ	60-70KΩ

Table 01: Measurements of Flex Sensor

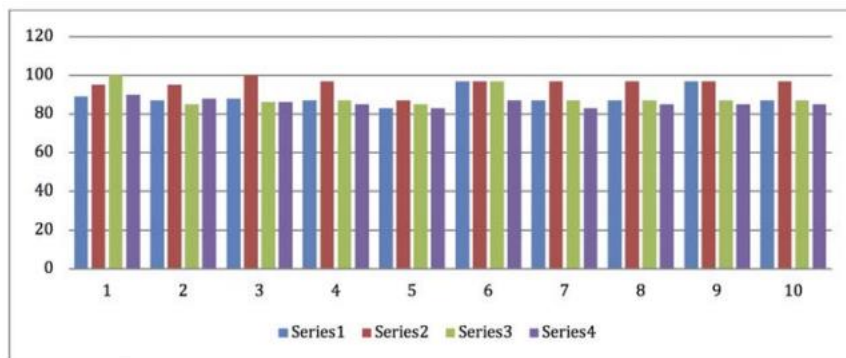

Figure 05: Bar Chart Representing Hand Flexion Readings of Healthy Individuals in Degrees.

Fig 05 represents the data of 10 healthy subjects in the form of a bar chart Person 5 is observed to exhibit the lowest reading and person 6 has highest of all readings. It represents the bar chart where different colors of the bars pertain to flexion readings in degrees acquired from the four fingers of healthy individuals. The four fingers include the index, middle, ring and baby finger.

Finger Name	Subject 1	Subject 2	Subject 3	Subject 4	Subject 5	Subject 6	Subject 7	Subject 8	Subject 9	Subject 10
Index	78	78	78	78	66	85	78	78	85	78
Middle	85	85	90	85	78	86	85	85	85	85
Ring	90	73	78	78	72	85	78	78	78	78
Baby	84	78	78	73	66	78	67	72	72	72

Table 02: Flexion Readings of Healthy Individuals

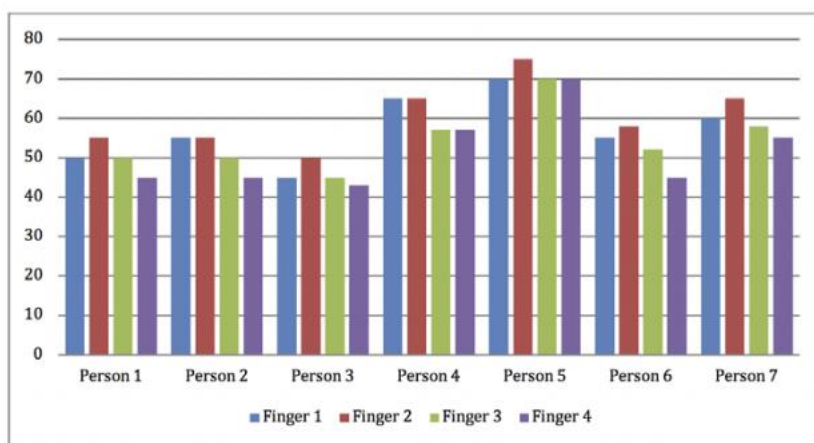

Figure 06: Bar Chart Representing Seven Stroke Patients' Flexion Readings in Degrees.

Table 02 exhibits flexion readings of ten healthy individuals in degrees measured from this smart glove. Table 3.2 demonstrates that flexion readings of ten healthy subjects were observed to be between seventy and ninety degrees. It exhibits the flexion readings in the form of a bar chart. It can be observed that the lowest flexion reading was generated by subject 3 and the highest by subject 5.

Finger Name	Subject 1	Subject 2	Subject 3	Subject 4	Subject 5	Subject 6	Subject 7
Index	45	50	40	60	70	50	60
Middle	50	50	45	60	75	55	65
Ring	45	45	40	55	70	45	55
Baby	40	40	35	55	70	40	50

Table 03: Flexion readings of seven stroke patients

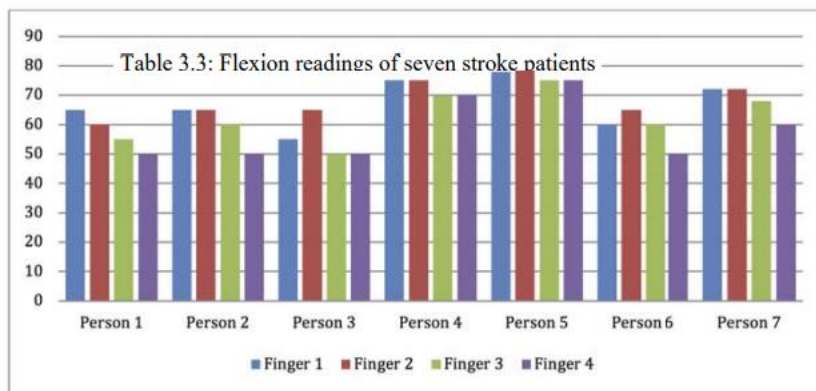

Figure 07: Bar Chart Representing Flexion Readings of Seven Stroke Patients after Receiving Rehabilitative Treatment for 15 Days

It can be observed from Table 3.3 that subject 3 generated the lowest flexion reading and subject 5 generated the highest reading. The readings of the seven stroke subjects were found to be in range of 35 and 75 degrees.

Finger Name	Subject 1	Subject 2	Subject 3	Subject 4	Subject 5	Subject 6	Subject 7
Index	55	55	45	65	75	50	65
Middle	50	55	55	65	80	55	65
Ring	45	50	40	60	70	50	55
Baby	40	40	40	60	70	40	50

Table 04: Flexion readings of the seven stroke patients after receiving rehabilitative treatment for 15 days

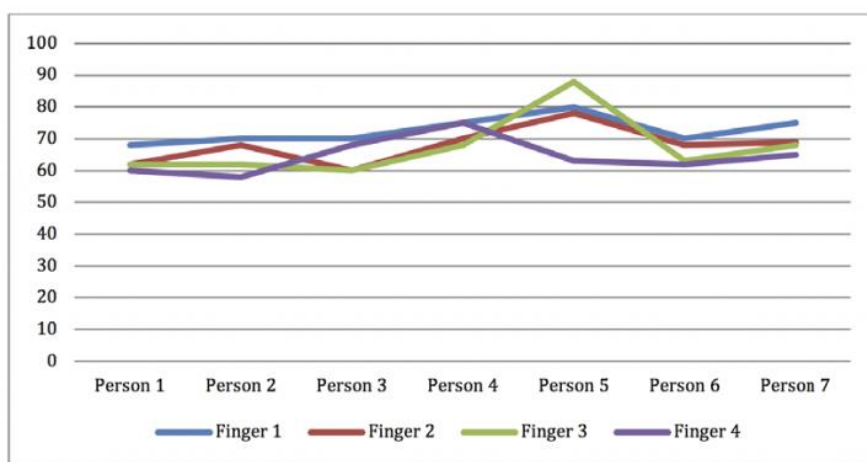

Figure 08: Line Chart Exhibiting Comparative Analysis of Data Points Acquired from Patients Before and After 15 Days of Therapy

The readings are demonstrated in Table 04. Significant changes were observed because of the continuous rehabilitation therapies that the subjects were adhering to. Table 04 exhibits

that the seven subjects are recovering rapidly as significant change in flexion values has been observed.

Fig 08 is used for drawing a comparative analysis. Flexion readings in degrees have been represented on y axis and x axis represents subjects. For subject 1 the angle of first finger increases after 15 days showing significant improvement in flexion. Same improvement is seen for other fingers. It is concluded that angle increases as a result of continuous physical therapy activities. Improvement can be observed through our designed glove and future hand assessment can also be executed effectively. Results also show that angle of flexion is greater for index finger as compared to baby finger.

	Subjects 1	Subjects 2	Subjects 3	Subjects 4	Subjects 5	Subjects 6	Subjects 7	Subjects 8	Subjects 9	Subjects 10
Gender	Male	Male	Female	Female	Female	Female	Male	Male	Female	Male
Pinching Force in N	147	156.8	127.4	98	166.6	117.6	127.4	186.2	137.2	156.8
Pinching Force in kg	15	16	13	10	17	12	13	19	14	16

Table 05: Pinching strength in Newton and Kilograms

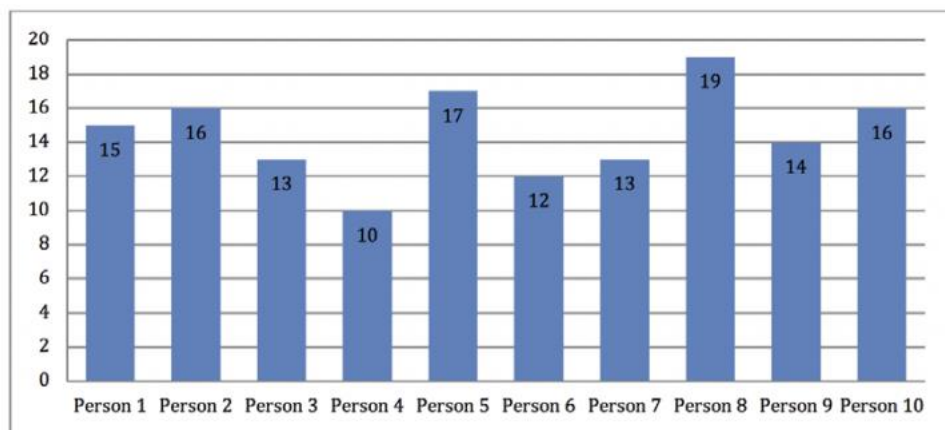

Figure 09: Pinching Strength Expressed In Kilograms (Kg)

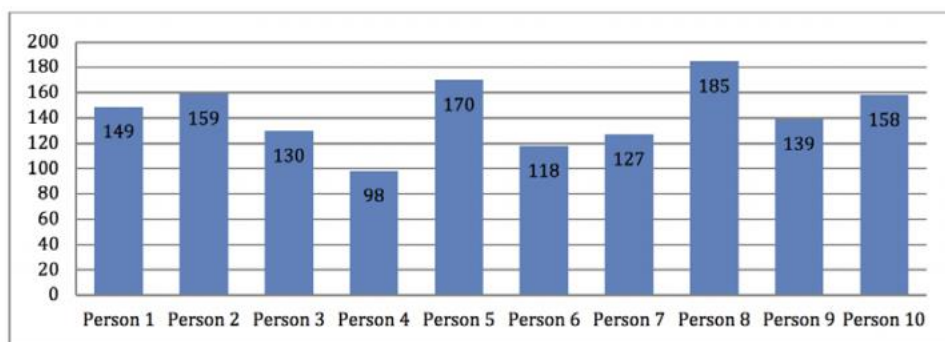

Figure 10: Pinching Strength Expressed in Newton

Table 05 and Fig 09 exhibit the pinching strength in Kilograms while Fig 10 demonstrates the results in Newton.

Outcome Measures

Ten Patients of the same hospital were recruited for observing their tip pinch strength. 5 were male and 5 were female. Table 3.5 and Fig 3.5 and Fig 3.6 show that male subjects have greater pinch strength as compared to female subjects. Person 1, 2, 7, 8 and 10 are

male subjects while person 3, 4, 5, 6 and 9 are female subjects. It also concluded that pinch strength decreases with increasing age. Fig 3.5 exhibits the pinching strength in Kilograms while Fig 3.6 demonstrates the results in Newton.

Discussion

The objective of this study was to design a glove possessing the ability to measure the ROM and the pinch strength with the aid of flex sensors and force sensors. The glove is able to evaluate the effectiveness of rehabilitative treatments pertaining to a patient functional impairment. Furthermore, the glove generates readings readily and reduces the execution time.

Accurate measurement of ROM of the fingers and pinching strength is necessary in analyzing upper limb therapies pertaining to functions for diagnosis, pre and post planning of the rehabilitative treatment including prescription about drugs, stroke, surgeries and physical therapies. The measurements are vital for assessing treatment progress and patient condition. The examination of ROM of the fingers includes analysis of finger ROM involving assessment of the Metacarpophalangeal joints (MCP) and Proximal interphalangeal joints (PIP).

An overview pertaining to robotic and mechanical assistive devices being used for post stroke thumb rehabilitation was emphasized. Traditional methods of rehabilitation tend to enhance the costs involved and exert labor intensive strategies which are time consuming. Mechanical devices are being used for assessing rehabilitation outcomes of patients particularly, stroke survivors. However, the full potential of such devices is yet to be unveiled²². Comparing our results with²², it can be concluded that we have designed an effective AT device that can measure both ROM and pinching strength following rehabilitative therapies. Hand prosthesis referred to as. A study proposed upper limb prosthesis referred to as the BrightArm Duo for analyzing the grasp strength and wrist position of chronic stroke survivors. Results of the study exhibited improvement in shoulder ROM and shoulder grasp strength among seven participants²³. Inertial sensors were utilized for measuring the lower limb joint ROM of healthy adults, stroke survivors and in patients with knee osteoarthritis. The results of these studies exhibited that an inertial sensor system is able to measure major joint angles as well as the ROM for stroke survivors and patients suffering from knee osteoarthritis^{24, 25, 26}. Comparing^{24, 25, 26} with our work, it can be concluded that our designed smart glove is effective in evaluating the ROM of stroke survivors both before and after adhering to rehabilitative treatment regimens.

Conclusion

There are numerous tools for monitoring and measuring ROM of the joints of finger as well as the pinching strength. Nonetheless, these devices require assistantship for the patient, are time consuming, expensive and tend to be less accurate. Also, these devices can measure only one joint at a time and cannot be used if there is any injury in the finger or in hand. A smart glove-based measurement system for monitoring ROM and pinching strength is proposed. The smart glove consists of flex and force sensors that can be used to generate accurate readings of ROM and pinching strength for stroke survivors following post stroke rehabilitation therapies. This smart glove has several advantages in terms of accuracy, time and comfort. The smart glove can be easily used by less skilled individuals and does not require sufficient training. Also, this smart glove is very comfortable to use,

as it is light in weight and easy to don and doff without causing any injury and discomfort to the patient.

AUTHORS' CONTRIBUTION:

The following authors have made substantial contributions to the manuscript as under:

Conception or Design: Salman Muhammad Ilyas, Syed Faraz Jawed, Choudhary Sobhan Shakeel, Luqman Hashim Bawany, Rumaisa Amin

Acquisition, Analysis or Interpretation of Data: Salman Muhammad Ilyas, Syed Faraz Jawed, Choudhary Sobhan Shakeel, Luqman Hashim Bawany, Rumaisa Amin

Manuscript Writing & Approval: Salman Muhammad Ilyas, Syed Faraz Jawed, Choudhary Sobhan Shakeel, Luqman Hashim Bawany, Rumaisa Amin

All authors acknowledge their accountability for all facets of the research, ensuring that any concerns regarding the accuracy or integrity of the work are duly investigated and resolved.

ACKNOWLEDGEMENTS: Thanks to all participants.

INFORMED CONSENT: I have taken consent.

CONFLICT OF INTEREST: No conflict of interest.

FUNDING STATEMENTS: None declared

ETHICS STATEMENTS: Ethical concerns related to this study are to take the consent of an individual patient for pilot study in accordance with the Declaration of Helsinki. For this purpose, authors have performed the standard procedure required for ethical approval before performing the pilot study.

References

1. H. Gates, L. S. Walters, J. Cowley, J. M. Wilken, and L. Resnik, "Range of motion requirements for upper-limb activities of daily living," *American Journal of Occupational Therapy*, vol. 70, no. 1, pp. 7001350010p1-7001350010p10, 2016.
2. M. Pérez-Mármol et al., "Effectiveness of a fine motor skills rehabilitation program on upper limb disability, manual dexterity, pinch strength, range of fingers motion, performance in activities of daily living, functional independency, and general self-efficacy in hand osteoarthritis: A randomized clinical trial," *Journal of Hand Therapy*, vol. 30, no. 3, pp. 262-273, 2017.
3. G. Behm, A. J. Blazevich, A. D. Kay, and M. McHugh, "Acute effects of muscle stretching on physical performance, range of motion, and injury incidence in healthy active individuals: a systematic review," *Applied physiology, nutrition, and metabolism*, vol. 41, no. 1, pp. 1-11, 2016.
4. Tajika et al., "Relation between grip and pinch strength and pitch type in high school pitchers with and without elbow symptoms," *Journal of Orthopaedic Surgery*, vol. 28, no. 1, p. 2309499019890743, 2020.
5. Kinney, D. M. Goodwin, and L. Gitlow, "Measuring Assistive Technology Outcomes: A User Centered Approach," *Assistive Technology Outcomes & Benefits (ATOB)*, vol. 10, no. 1, 2016.
6. J. Scherer, "Enhancing appropriate use of adaptive/assistive technology," in *Practical Psychology in Medical Rehabilitation*: Springer, 2017, pp. 353-360.
7. C. Dewan et al., "Estimating the global incidence of traumatic brain injury," *Journal of neurosurgery*, vol. 130, no. 4, pp. 1080-1097, 2018.
8. Langan, H. Subryan, I. Nwogu, and L. Cavuoto, "Reported use of technology in stroke rehabilitation by physical and occupational therapists," *Disability and Rehabilitation: Assistive Technology*, vol. 13, no. 7, pp. 641-647, 2018.

9. Stephenson and J. Stephens, "An exploration of physiotherapists' experiences of robotic therapy in upper limb rehabilitation within a stroke rehabilitation centre," *Disability and Rehabilitation: Assistive Technology*, vol. 13, no. 3, pp. 245-252, 2018.
10. E. Dicianno et al., "The future of the provision process for mobility assistive technology: a survey of providers," *Disability and Rehabilitation: Assistive Technology*, vol. 14, no. 4, pp. 338-345, 2019.
11. Carmeli, B. Imam, and J. Merrick, "Assistive technology and older adults," in *Health care for people with intellectual and developmental disabilities across the lifespan*: Springer, 2016, pp. 1465-1471.
12. Sreejan and Y. S. Narayan, "A review on applications of flex sensors," *International Journal of Emerging Technology and Advanced Engineering*, vol. 7, no. 7, pp. 97-100, 2017.
13. N. Farooq, M. A. M. Bandpei, M. Ali, and G. A. Khan, "Reliability of the universal goniometer for assessing active cervical range of motion in asymptomatic healthy persons," *Pakistan journal of medical sciences*, vol. 32, no. 2, p. 457, 2016.
14. D. Hirschhorn, J. W. Lockhart, and J. D. Breckenridge, "Can a physical activity monitor provide a valid measure of arm elevation angle? A study to assess agreement between the SenseWear Mini Armband and the universal goniometer," *BMC musculoskeletal disorders*, vol. 16, no. 1, pp. 1-9, 2015.
15. P. McHugh, A. M. Morton, B. Akhbari, J. Molino, and J. J. Crisco, "Accuracy of an electrogoniometer relative to optical motion tracking for quantifying wrist range of motion," *Journal of medical engineering & technology*, vol. 44, no. 2, pp. 49-54, 2020.
16. C. Lim, M. Affandi, S. N. Basah, and M. Y. Din, "Evaluating lower limb joint flexion by computerized visual tracking system and compared with Electrogoniometer and universal goniometer," *Journal of Telecommunication, Electronic and Computer Engineering (JTEC)*, vol. 10, no. 1-4, pp. 9-14, 2018.
17. J. Otter et al., "The reliability of a smartphone goniometer application compared with a traditional goniometer for measuring first metatarsophalangeal joint dorsiflexion," *Journal of foot and ankle research*, vol. 8, no. 1, pp. 1-7, 2015.
18. Taylor and K. Curran, "Glove-based technology in hand rehabilitation," in *Gamification: Concepts, Methodologies, Tools, and Applications*: IGI Global, 2015, pp. 983-1002.
19. Devi and S. Deb, "Low cost tangible glove for translating sign gestures to speech and text in Hindi language," in *2017 3rd International Conference on Computational Intelligence & Communication Technology (CICT)*, 2017: IEEE, pp. 1-5.
20. J. Wachter, M. Mentzel, C. Haederer, G. D. Krischak, and J. Guelke, "Change in the temporal coordination of the finger joints with ulnar nerve block during different power grips analyzed with a sensor glove," *Hand Surgery and Rehabilitation*, vol. 37, no. 1, pp. 30-37, 2018.
21. da Cruz Teixeira and J. C. de Oliveira, "Right hand rehabilitation with cyberforce, cybergrasp, and cyberglove," in *2015 XVII Symposium on Virtual and Augmented Reality (SVR)*, 2015: IEEE Computer Society, pp. 186-189.
22. Suarez-Escobar and E. Rendon-Velez, "An overview of robotic/mechanical devices for post-stroke thumb rehabilitation," *Disability and Rehabilitation: Assistive Technology*, vol. 13, no. 7, pp. 683-703, 2018.
23. House et al., "Integrative rehabilitation of residents chronic post-stroke in skilled nursing facilities: the design and evaluation of the BrightArm Duo," *Disability and Rehabilitation: Assistive Technology*, vol. 11, no. 8, pp. 683-694, 2016.
24. Lebleu, T. Gosseye, C. Detrembleur, P. Mahaudens, O. Cartiaux, and M. Penta, "Lower limb kinematics using inertial sensors during locomotion: accuracy and reproducibility

- of joint angle calculations with different sensor-to-segment calibrations,” *Sensors*, vol. 20, no. 3, p. 715, 2020.
25. Lebleu et al., “Lower limb kinematics improvement after genicular nerve blockade in patients with knee osteoarthritis: a milestone study using inertial sensors,” *BMC Musculoskeletal Disorders*, vol. 21, no. 1, pp. 1-12, 2020.
 26. Rajkumar, F. Vulpi, S. R. Bethi, H. K. Wazir, P. Raghavan, and V. Kapila, “Wearable inertial sensors for range of motion assessment,” *IEEE sensors journal*, vol. 20, no. 7, pp. 3777-3787, 2019.



© Pakistan Journal of Rehabilitation. This article is published under the terms of the Creative Commons Attribution 4.0 International License (CC BY 4.0), which permits unrestricted use, distribution, and reproduction in any medium, provided the original author(s) and source are properly cited. [Creative Commons Attribution License \(CC BY 4.0\)](https://creativecommons.org/licenses/by/4.0/)